

LED SHOEBOX LIGHT



PRODUCT DESCRIPTION

This light's cutting edge optical design provides superior illumination and precision glare control. The unique cooling channel design promotes efficient heat dissipation and ensures a longer lifespan whether you have a new construction or upgrade application.

Applications: Parking lots, roadways, walkways, and general sites

ACCESSORIES

Arm
Mount
Bracket



Slip
Fitter
Bracket



Trunnion
Bracket



DIMENSIONS

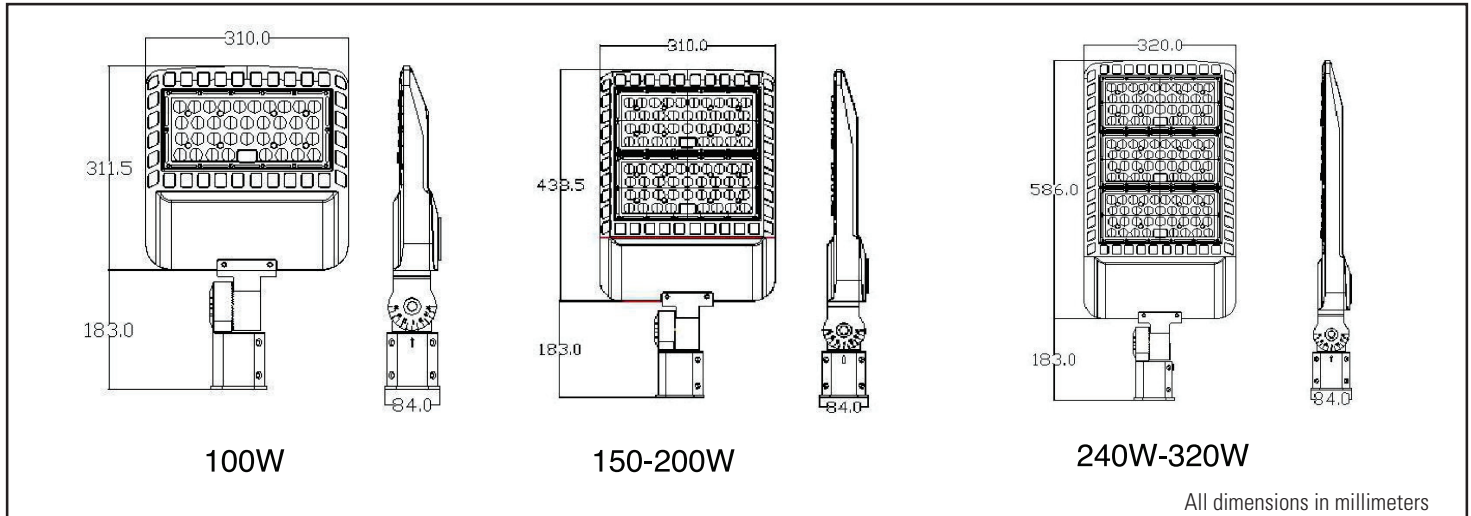

SPECIFICATIONS

Part Number	Input Power	Input Voltage	Efficiency	CCT	Light Distribution	CRI	Certificates	Warranty
JH-SBD100W-82F	100W	100-277VAC	120Lm/W	4000-5700K	TYPE II/III/IV/V	75	UL, DLC, RoHS	5 Years
JH-SBD150W-82F	150W	100-277VAC	120Lm/W	4000-5700K	TYPE II/III/IV/V	75	UL, DLC, RoHS	5 Years
JH-SBD200W-82F	200W	100-277VAC	120Lm/W	4000-5700K	TYPE II/III/IV/V	75	UL, DLC, RoHS	5 Years
JH-SBD240W-82F	240W	100-277VAC	120Lm/W	4000-5700K	TYPE II/III/IV/V	75	UL, DLC, RoHS	5 Years
JH-SBD320W-82F	320W	100-277VAC	120Lm/W	4000-5700K	TYPE II/III/IV/V	75	UL, DLC, RoHS	5 Years